

### A Extractor fan, system 4, 240V

- Complies with 1995 Building Regulations on ventilation
- Easy to install
- Extracts up to 85 m<sup>3</sup> per hour, 23 litres per second
- Noise level: 41.0 db (A)
- White ABS Plastic

Operation	Cat. No
Switch	828.02.701
Pull chord	828.02.711
Timer	828.02.721

Order qty: 1 pc

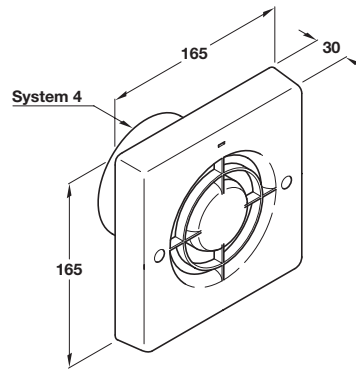

### B Extractor fan, system 5, 240V

- Complies with 1995 Building Regulations on ventilation
- For larger bathrooms, toilets, utility rooms etc.
- Easy to install
- Extracts up to 130 m<sup>3</sup> per hour, 36 litres per second
- Noise level: 41.0 db (A)
- White ABS Plastic

Operation	Cat. No
Switch	828.02.702
Pull chord	828.02.712
Timer	828.02.722

Order qty: 1 pc

